

# THE ARUP JOURNAL

DECEMBER 1971



The Shahyad Ariamehr pedestrian underpass, by J. Harvey, R. Afia and P. Evans	2
Notes on the design of cable roofs, by P. Rice	6
Stressed rock-anchor antenna-support towers, by R. Kelman and H. Holmes	10
The calculation of earth pressure in open cuts in soft clays, by D. Henkel	13

Front cover: Persian builders at work (From a Persian MS., about AD 1494) Reproduced with the permission of the British Museum.

Back cover: Interior of the arch of the Shahyad Ariamehr (Photo: Duncan Michael)

## The Shahyad Ariamehr pedestrian underpass

John Harvey,  
Robert Afia and  
Peter Evans

**Architects: Hossein Amanat and Associates**

**Main Contractor: MAP Company**

### Introduction

The Shahyad Ariamehr monument, built to commemorate the 25th centenary of the foundation of the Iranian Empire, stands near the centre of a large roundabout on the outskirts of Tehran on the main dual carriageway leading to and from the airport. The site is therefore ideal for the purpose of displaying a structure designed to be viewed from a distance and from all directions, but presents a problem in facilitating pedestrian access across the traffic 'moat' to the base of the monument and into the surrounding ornamental gardens. Of the two possible solutions, a tunnel beneath or a bridge over the six lane carriageway, the latter was presumably considered inappropriate as the span and pedestrian capacity would dictate a structure of a size which would constitute a significant obstruction and distraction to the view of the monument itself. Our brief, therefore, was to design a tunnel structure having a shape and internal surface configuration determined by the architects for the monument project, Hossein Amanat and Associates.

### Geometry

The general plan configuration is of three similar tunnel arms radiating at 120° centres from a central dome area connecting the east side of the roundabout to both the north and south sides of the eastern approach and exit

way flanks are identical stair and ramp wells placed skew to the tunnel centre line to follow the kerb line above, while the entrance from the roundabout is from a low level concourse at tunnel floor level. The central dome roof level rises above ground in the carriageway central reservation and a parapet opening provides natural lighting and ventilation to the tunnel below.

As the overall shape and internal surface geometry are perhaps most readily appreciable from the drawings, only a brief overall description is given here. As the basis for the geometry, four setting out points are established; three on the apexes of an equilateral triangle of side length 80 m, and the fourth at the centroid of this triangle. The tunnel on plan at floor level occupies the area contained between circular arcs of radius 36 m swung from the three apex setting out points. Lines drawn through the centroidal setting out point perpendicular to the sides of the original triangle define the longitudinal axes of the tunnel arms so formed. Three further circular arcs, concentric with, but of greater radius than, the first, define the boundaries of the roof. The roof surface is horizontal at all points around these boundaries but varies in level within, both along the tunnel arms and in particular in the central area where it rises to form the parapet to the opening at ground level. Within this basically curved setting out network the internal wall and roof surfaces are made up entirely of flat planes intersecting (therefore) along straight lines. The walls which are of constant height and inclined inwards towards the roof follow the circular setting out curves at floor and roof level in a series of equal chords, the length of which are defined by a 30° arc from the central setting out point. The roof surface is entirely composed of triangular planes, the apexes of which are defined on plan as points of intersection of circular arcs and radial lines from the four original setting out points.

### Structural proposals

The tunnel shape suggested two alternative 'optimum' structural systems; firstly that the planar configuration should be abandoned in

favour of the continuously curved surface to which it approximates to take fullest advantage of the basic shape to derive in-surface strength; or secondly to develop the hipped plane principle further and so, by increasing the hip and valley angles, to produce a folded plate structure of high flexural strength. Both possibilities were put to the architect in principle but neither was acceptable as each changed the geometry significantly. The simplest structure of a constant thickness reinforced concrete slab following the specified geometry was considered but the steepness of the walls is such that little resistance to lateral thrust could be developed at the roof springing and the advantage of the vaulted and domed roof shape is wasted. The possibility of reinforcing the roof slab with a network of upstanding beams was investigated but was abandoned primarily because of the geometric difficulties in fitting such a structure beneath road formation level in the area of the central dome, although an additional disadvantage inherent in the use of upstanding beams is that the roof slab, lying in the lower tensile zone of these beams, may be subject to cracking through its full depth which would lead to waterproofing problems, lying as it does in a permeable granular material subject to vibration.

The structure finally adopted uses external buttresses to provide the thrust resistance to the roof arch. It was originally envisaged that the buttresses would rise from inclined foundations transferring the thrusts directly to the ground, but in view of the possibility that future excavations (perhaps for services adjacent to the carriageway) might disturb the ground in these areas with perhaps calamitous results, the foundation system was changed to horizontal pads tied across the tunnel floor.

### Analysis

The traditional triangular panels were very convenient as far as modern day methods of structural analysis were concerned—being almost ready-made finite elements.

Preliminary calculations had been carried out at the scheme design stage by hand, approximating the structure to a series of portal

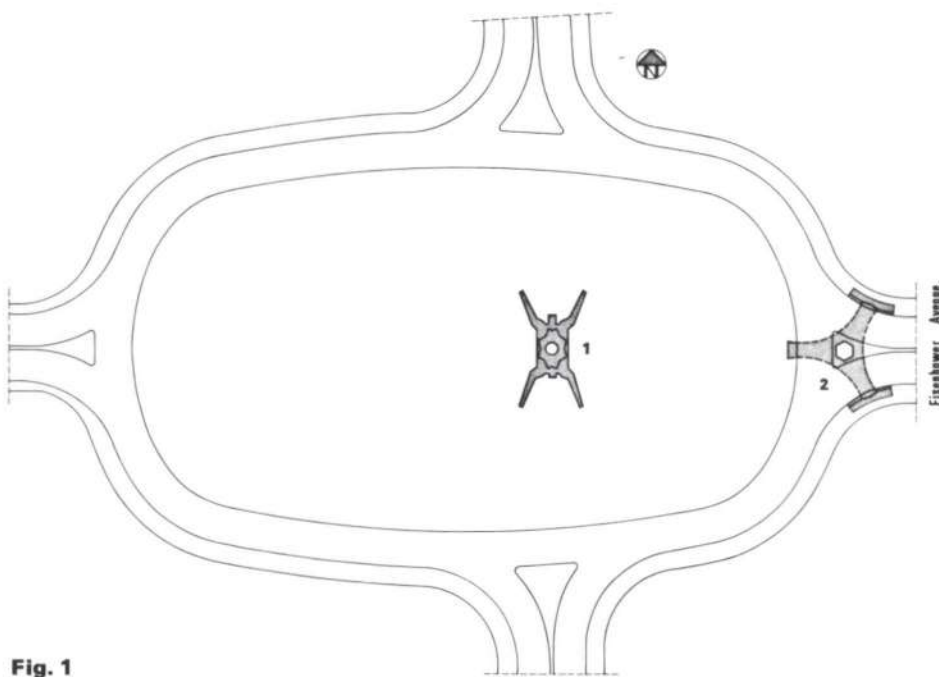

**Fig. 1**  
Site plan  
1. The monument

2. The underpass

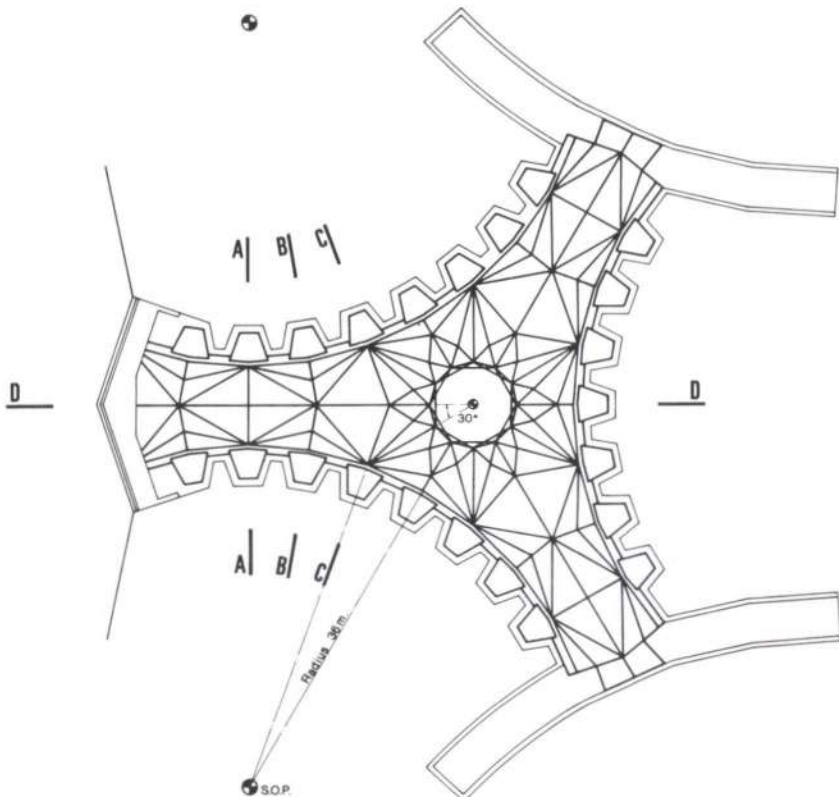

**Fig. 2**  
Plan on underpass showing setting out points (s.o.p.)

frames, and on the computer using a space-frame analogy (program OA102). These results enabled suitable section sizes to be chosen and used in the final analysis. A three dimensional plate bending and shell analysis finite element program, developed at Swansea University, was used. The finite element method considers a continuous system to be composed of a number of separate masses, which may be two or three dimensional and can have various shapes, interconnected at nodal points. The analysis is based on the structural stiffness method using matrix notation.

The symmetry of the structure meant that only a sixth portion need be analysed and the original triangles were further subdivided to give a finer mesh for more accurate results.

The program enabled the exact geometry of the roof, walls and buttresses to be simulated in the data.

Three loading conditions were considered:

- 1 Self weight of the structure
- 2 Overburden
- 3 Superload from traffic.

Uniformly distributed loads are replaced in the data by a series of point loads acting at the node points of the triangular elements.

Temperature effects on the exposed part of the dome were considered separately and the parapets reinforced accordingly.

Geometric data is always very prone to error and a check was carried out using a computer perspective plot. The mistakes were corrected and the final run executed.

The output gave results for each load case listing foundation reactions, nodal displacements, element bending moments and membrane forces. Plots were made of this data to give a visual representation of the behaviour of the structure.

The computer analysis was very useful and the plots gave a good appreciation of the structural action, i.e. the stiffening effect of the ridges especially around the dome and the way the loads channelled down to the buttresses to combine arch and frame action across the section.

The results were used to specifically check:

- 1 Bearing pressures and tie forces across the floors from the foundation reactions
- 2 Final concrete stresses to confirm the adequacy of the sections chosen from the preliminary calculations
- 3 Bending moments across and along the sections and the reinforcement required to accommodate these moments.

### Detailing

The unusual roof geometry with its numerous planes intersecting along converging ridges and valleys presented special problems in the reinforcement detailing. For instance, if at every line of discontinuity the standard corner detail (where the inner layer of steel from either direction passes into the outer layer) had been used, a large proportion of the steel would have been employed in bond and lap lengths. The triangular modulation would also have dictated a continuous variation of bar lengths producing a major prebending headache to say nothing of the labours of scheduling. To overcome these difficulties, the inner and outer reinforcement layers were detailed as independent mats passing continuously over valleys and ridges composed of small diameter bars scheduled straight to be bent on site over the erected formwork, with the exception of bars crossing valleys, which were scheduled bent to avoid the practical difficulty of bending a bar accurately into a formwork valley. A maximum bar diameter of 12 mm was used to facilitate in situ bending and bars were bundled in threes throughout to facilitate concrete placement.

In order to prevent bursting of the inner mat of steel at ridges and the outer mat at valleys, the two layers were linked along these lines by providing straight longitudinal bars parallel to the line of discontinuity in the cover thickness to each mat and interconnecting these bars at regular centres by 'hairpin' links of 8 mm bar bent in place.

The remainder of the detailing followed fairly conventional lines except that the steel passing from the walls into the roof was also affected by the varying roof profile. Here large diameter bars were used but, to avoid prebending these bars to each separate roof angle, an upstand was introduced above the wall to accommodate the lap between standard wall bars and roof steel approaching from different angles.

### Construction

In spite of its shape, the construction of the underpass was fairly conventional, and gave no extraordinary problems to the contractor, the MAP Company.

The closure of one carriageway of Eisenhower Avenue, together with the construction of a temporary by-pass of the underpass area to take the diverted traffic, led to the decision to construct two of the three legs in the first stage. One was the west leg giving the contractor easy access from within the roundabout. In the second stage, with traffic running over the two legs already constructed, the other carriageway would be closed and the third leg of the underpass formed.

Excavation by loader was extremely easy in the typical Tehran sandy gravel which also has enough cohesion to stand up vertically for the depth of excavation needed for the

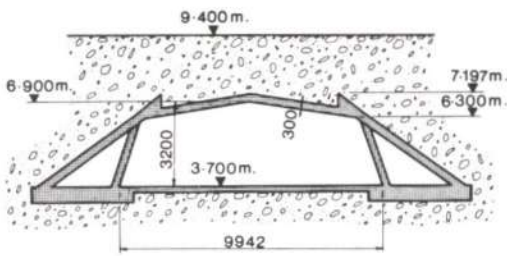

**Fig. 3**  
Section A-A

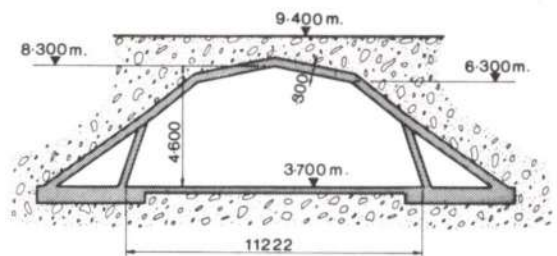

**Fig. 4**  
Section B-B

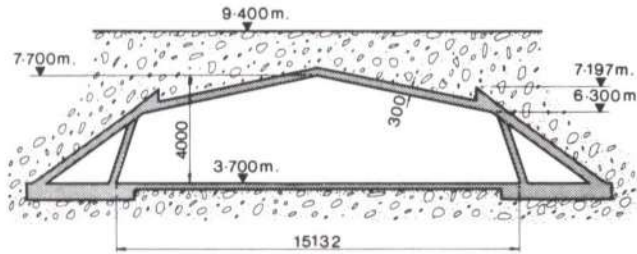

**Fig. 5**  
Section C-C

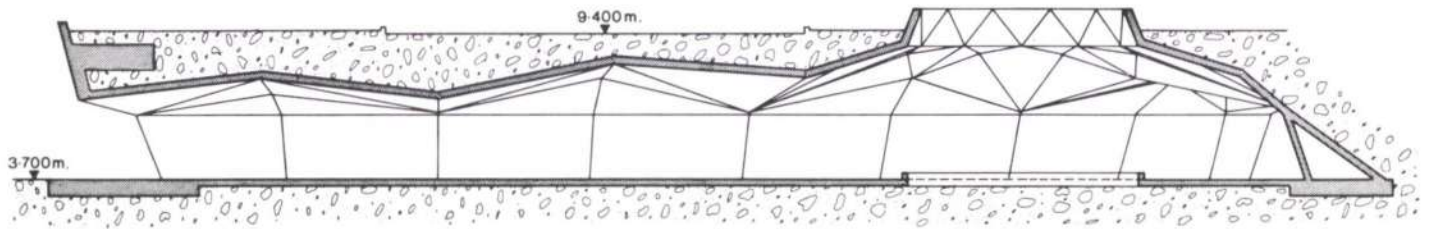

**Fig. 6**  
Section D-D

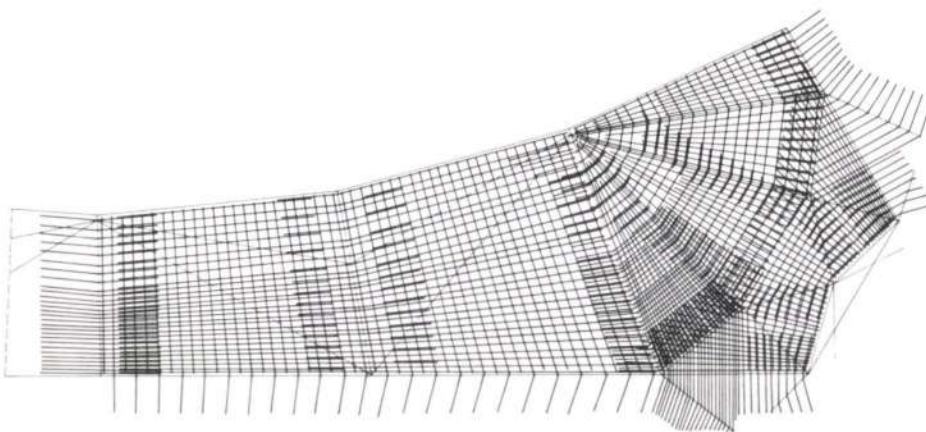

**Fig. 7**  
Portion of top mat of reinforcement. Each line represents a bundle of three 12 mm bars

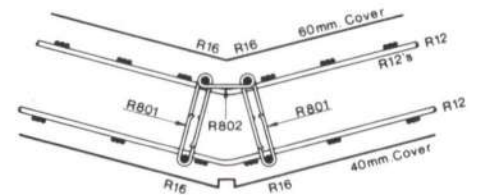

**Fig. 8**  
Valley reinforcement detail

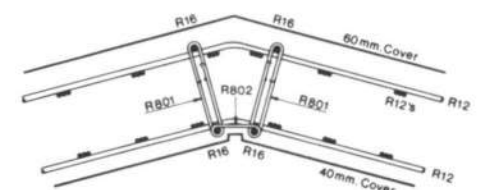

**Fig. 9**  
Ridge reinforcement detail

underpass. This allowed the contractor to place his mobile concrete mixer and stocks of sand and gravel on the tarmac road right at the edge of the excavation. The concrete was then dropped by chute down to the foundations, and horizontally by a rail wagon system to the walls and roof.

The buttresses, which were concreted at the same time as the walls, proved a little difficult to form because of their slope. They were steep enough to require a top shutter, but not steep enough to allow the concrete to flow down the shutter easily. The problem was exacerbated by the amount of reinforcement. By using two strong vibrators close together, and a lot of supervision to ensure that no part was missed out, good results were achieved.

The roof has an exposed concrete soffit, and the shuttering took the form of boards with a 'vener' of 6 mm plywood laid out to a deliberate arrangement. The 'ridge' and 'valley' lines between the triangular roof segments were emphasized by a groove, which also formed the basis for construction joints where they occurred.

Assembly of the roof reinforcement worked out well in practice. Bending the 12 mm bars in threes in situ on the shuttering proved easy, and in those cases where 16 mm bars were substituted to increase the spacing even this diameter gave no problems. The special 'ridge' and 'valley' reinforcement detail also proved to be practical. It was anticipated that the reinforcing methods used might cause some shutter damage with resultant poor finished surfaces and certainly some damage did occur; however it was not clear that the cause was the reinforcing method, and in any case the damage was not excessive.

Backfilling was only commenced when the first two legs and the central 'dome' area were all complete. Then the two legs only were backfilled, evenly on both sides of the legs, and evenly longitudinally along the legs, to avoid differential loadings.

**Conclusion**

The Shahyad Ariamehr monument was officially opened (inaugurated) by the Shah of Persia during the celebrations held during October.

**Photos:**

**Fig. 10a**  
Buttress reinforcement

**Fig. 10b**  
Reinforcement round the dome

**Fig. 11**  
Interior of tunnel

**Fig. 12**  
The underpass during construction from the top of the Shahyad Ariamehr

**Fig. 13**  
The completed monument  
(Photo: Copyright Syndication International)

**Figs. 10a, 10b, 11 and 12**  
(Photos: Robert Afia)

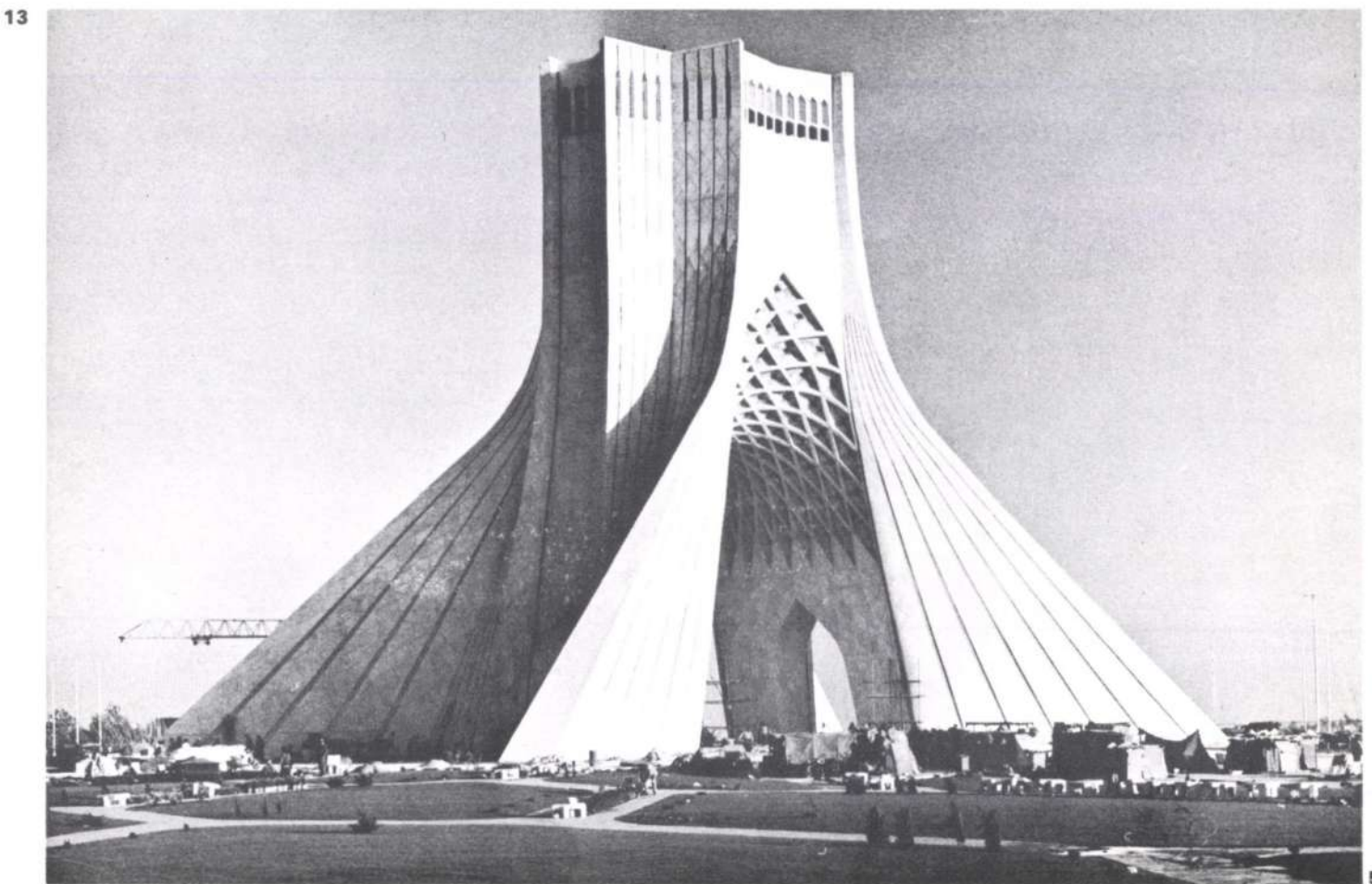
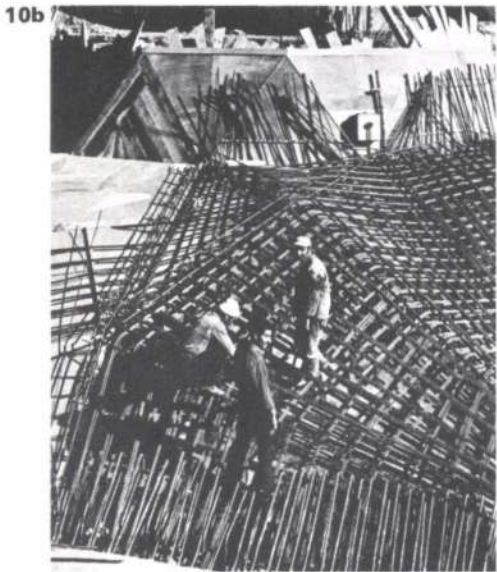
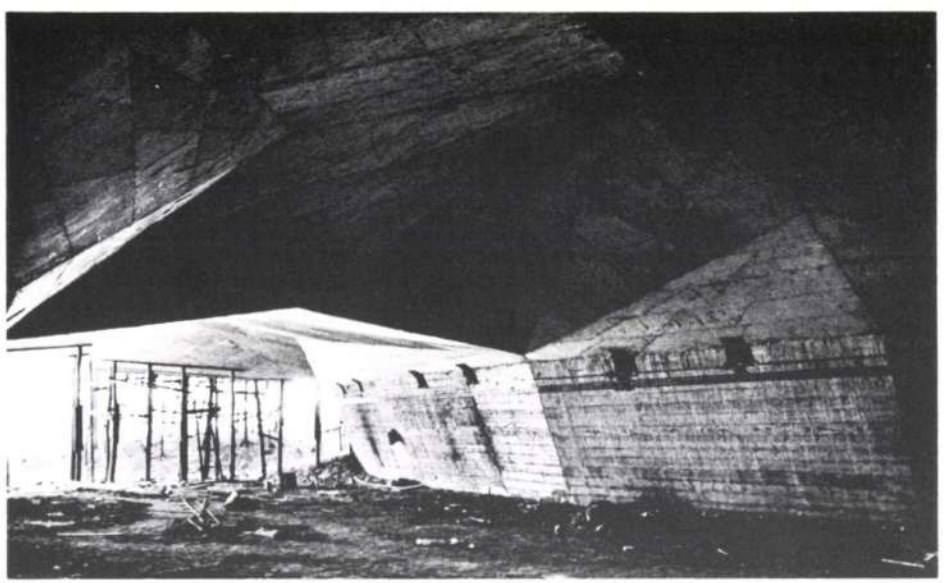
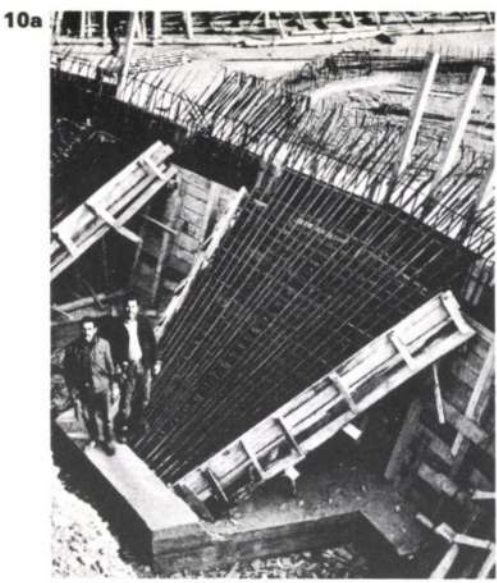

# Notes on the design of cable roofs

Peter Rice

*This paper was given at the International Association for Shell Structures Pacific Symposium; Part 2: Tension structures and space frames, which was held in Tokyo and Kyoto, Japan, 17–23 October, 1971.*

## Summary

The design of cable roofs consists of specifying a compatible geometry, choosing the right materials and designing all the bits and pieces. All designers have an attitude towards the things they design. This paper describes the attitude of one designer. It describes how three unsymmetrical cable roof geometries were defined without the use of models. It describes the evolution of the geometrical shape of the third roof and it discusses the factors which govern the selection of manufacturing tolerances, the choice between rope and strand and the design of fittings. It starts from the premise that cable roofs are meant to be flexible and that they should be specified exactly for manufacture.

## Introduction

What does design mean? It is essential to define at least approximately what one means by the design of cable roofs before there can be a meaningful discussion. The designer, faced with a problem, starts with an attitude. This attitude is the product of his experience and his interpretation of it. When one writes a paper entitled 'Notes on the design of cable roofs' one is codifying an attitude, selecting those experiences which have formed it, and describing how and why they have relevance to the general problems. There is, of course, a body of fact. The Young's modulus of steel rope is a fact. Whether or not rope is a more suitable material than spiral steel strand is in the end an attitude. The answer will vary from problem to problem and from designer to designer. There are other factors in the design process which cannot be codified: imagination and flair are two. These are not the subject of this paper.

One asks again, and now with particular reference to cable roofs, what does design mean?

It means defining a geometry that is economic and feasible, a geometry which exists and will resist the applied loads in a reasonable fashion, without local soft points, without high stress concentrations. There are, of course, simple geometries, where there is little problem. It is the more complex geometries

which are of interest, such as the roof of the Olympic stadium in Munich or Professor Frei Otto's roof at Mecca (Fig. 1).

It means choosing the right materials. The size or strength is not really too difficult. It is choosing the stiffness that can cause difficulties. Should it be rope or strand? The correct size and stiffness of beams in a structure such as the Mecca roof is also very much a design decision.

It means specifying a set of cable lengths which, when manufactured and assembled, become the roof.

It means defining the building process so that we can understand the available tolerances and the effect inaccuracy of manufacture will have on the final structure.

It means designing anchorages, clamps and other connections. It means choosing the level of prestress.

It means analysis; checking the final structure for the effects of applied loads; checking overall effects such as dynamic stability; in wind and under other periodic loads.

It means other things such as the choice of suitable cladding materials, the connection between the flexible cable roof and the surrounding rigid structures, the choice of a site and the location and design of the anchorages, etc., but the list is already long enough. Even then only some of the things

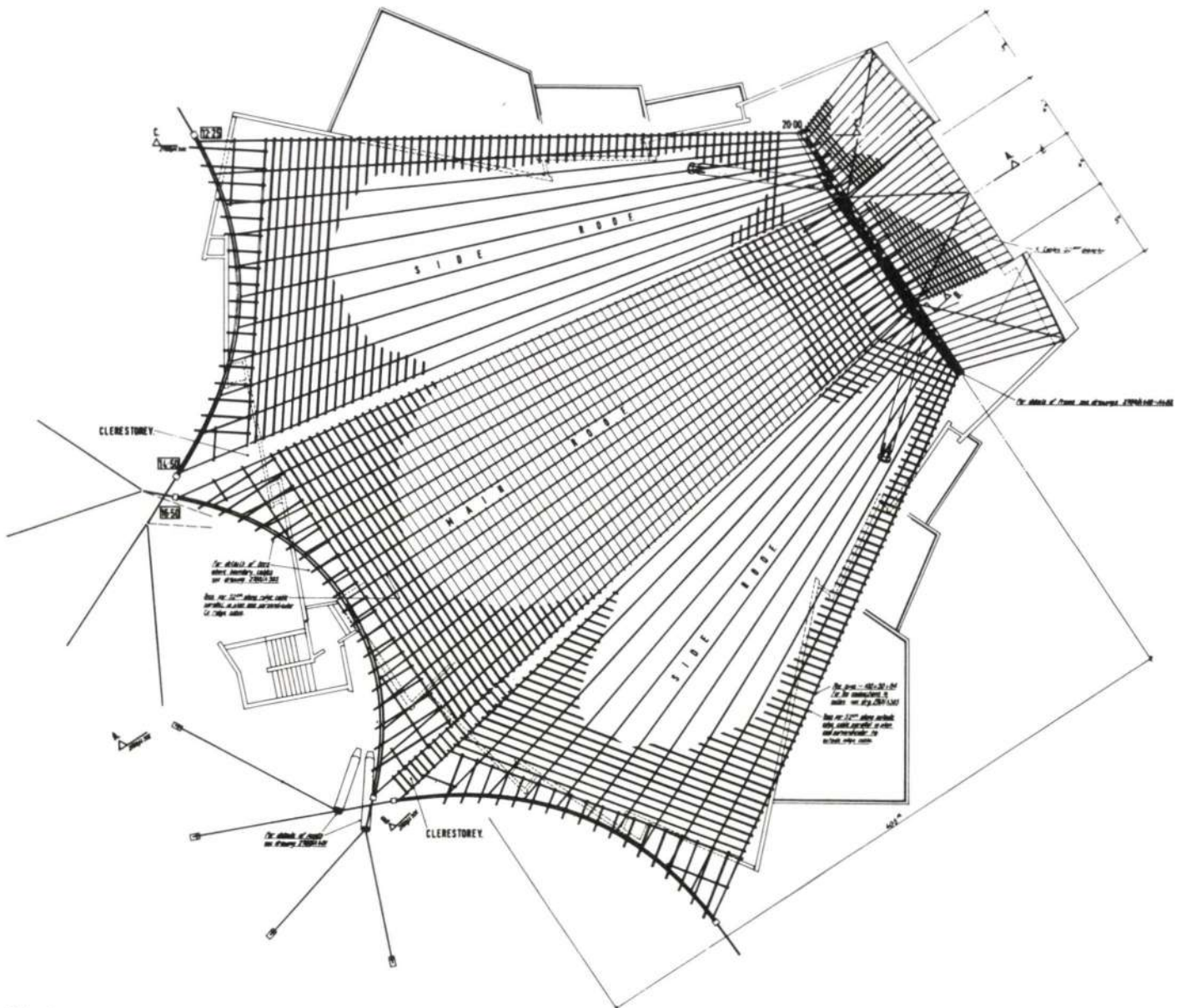

**Fig. 1**  
Plan of Auditorium—Mecca Conference Centre and Hotel

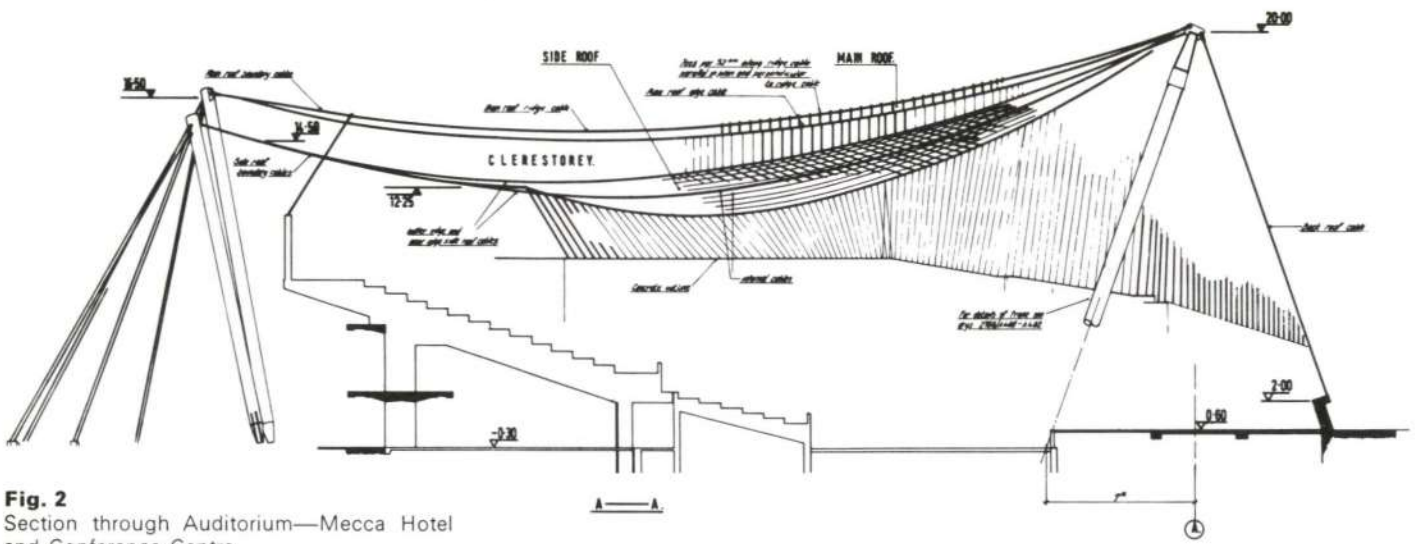

**Fig. 2**  
Section through Auditorium—Mecca Hotel  
and Conference Centre

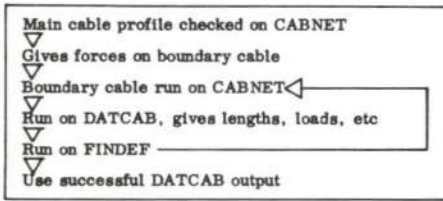

**Fig. 3**  
Flow diagram for hanging roof

can be dealt with, some aspects of some of the problems. In the discussion which follows, I have tried to limit the description to those things where there are at least some facts to relate.

The beginning is the shape. In general terms three types of shape are used:

- (1) The anti clastic curvature broadly based on the hyperbolic paraboloid, or on minimum tension nets
- (2) Heavyweight cable roofs of regular or irregular shape
- (3) Prestressed cable trusses, either with or without shear stiffness

These can be irregular in shape (Fig. 4 Mecca Conference Oasis—Plan). With any of these systems the approximate design is easy. A simple funicular diagram of the most curved and the least curved areas will suffice to determine the general stress levels. The difficulties arise in defining the geometry exactly, particularly if the support is provided through boundary cables. How this was done on two irregular structures is now explained. One is the main Auditorium roof for the Hotel and Conference Centre at Mecca, Saudi Arabia (Architects: Rolf Gutbrod and Frei Otto) (Fig. 1) and the other is the radial cable trusses of the Conference Oasis Kafess (Fig. 4) also at Mecca. Model analysis, which is the most direct method for defining complex geometries, was not used. The use of models in this context is discussed elsewhere<sup>1</sup>. The generation of the geometry of a third structure, Hirst's Amphitheatre, is also described as it provided me with one or two surprises and leads quite well into a discussion on stiffnesses. Before beginning, it is relevant to say that I believe that cable roofs should be specified exactly for the manufacturer. To adjust a cable roof is not easy.

**Mecca Auditorium roof geometry**

The Mecca Auditorium roof (Figs. 1 and 2) is a heavyweight cable roof suspended from a steel frame at one end and at the other from boundary cables, which span between guyed masts. The roof has three panels, each of which is about 6 m across at the frame and spreads out to 25 m at the boundary cable

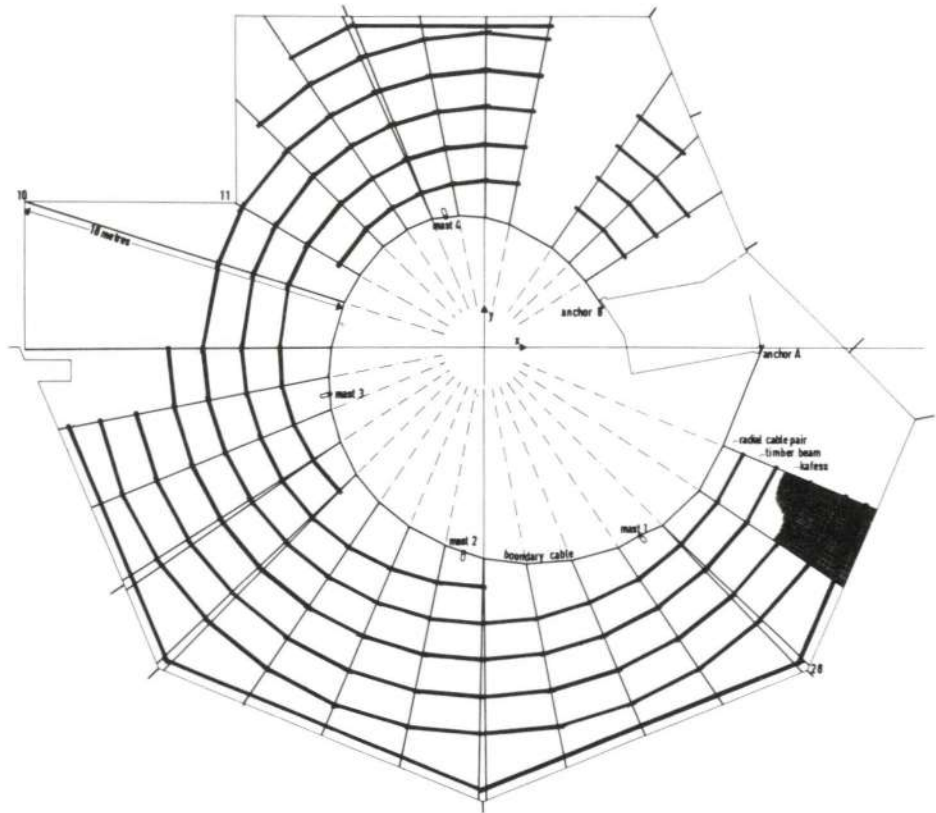

**Fig. 4**  
Plan of Conference Oasis Kafess—Mecca

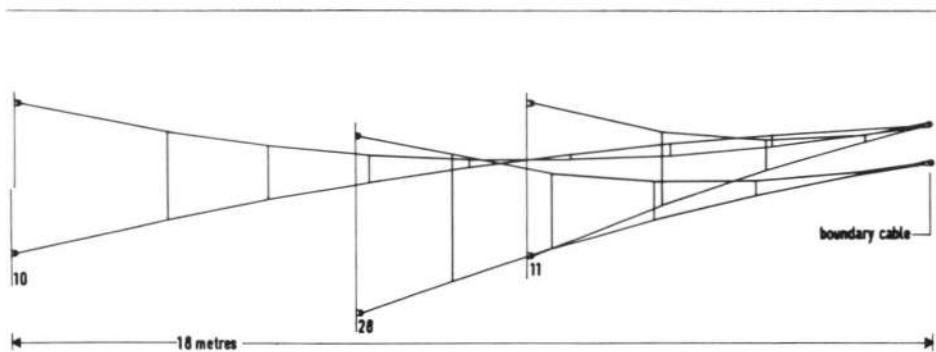

**Fig. 5**  
Profiles of three radials of Conference Oasis Kafess—Mecca

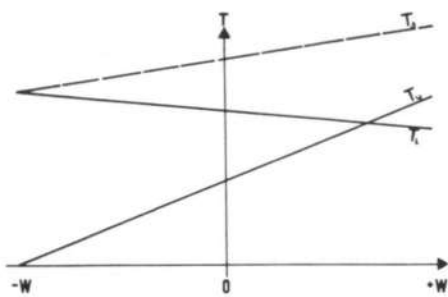

**Fig. 6**  
Prestress diagram

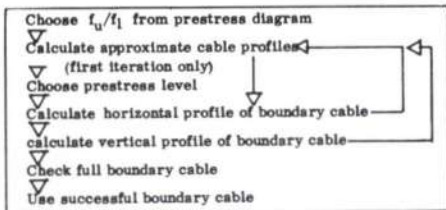
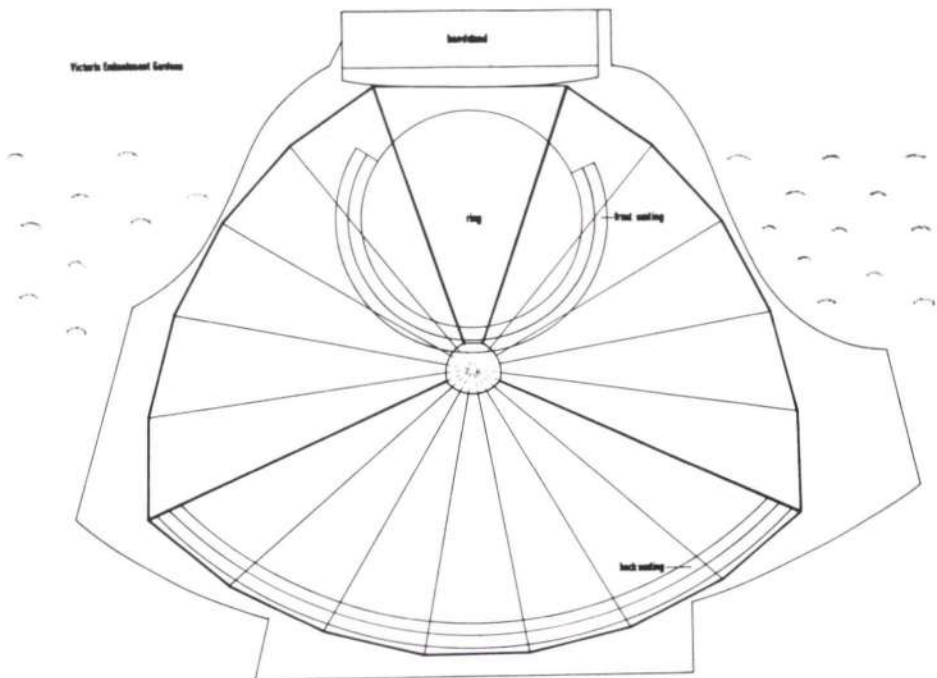

**Fig. 7**  
Flow diagram for prestressed roof

end. There is a ridge line in the centre of the centre panel and the roofs fall away to allow rainwater to flow away. A vertical clerestory connects the centre and side panels. The generators are 75 mm x 75 mm double angles spaced 500 mm apart. The cables are 26 mm strand.

When defining the geometry of a single cable, one needs to know the relative position of the two end supports, the pattern of load and the length. Here the frame support is known. At the other end the points of support of the boundary cable are known but the boundary cable profile is not known. This boundary cable profile cannot be found until the magnitude and direction of the applied cable forces are known. These require a knowledge of the boundary cable. On any of the roof panels the free cable profiles were incompatible with the straight generators. To establish the geometry, define the cable lengths and angle lengths, an iterative system was used. As part of the routine, two existing cable analysis programs were used. These were called CABNET and FINDEF. CABNET was a three dimensional cable network program using the method of steepest descent<sup>2</sup>. FINDEF was a three dimensional modified stiffness program developed at Manchester University by Dr. Brotton<sup>3</sup>. With FINDEF, bending stiffness can be mixed with cables.

The iterative procedure is shown in Fig. 3. Firstly, the approximate main cable profiles were checked by CABNET (the support at the boundary cable end was presumed to lie on the line between the tops of the two masts as the first approximation). An approximate boundary cable was defined and analysed under the main cable forces. This defined the boundary cable support points. These support points were then used to recalculate the main cable profiles. The modified forces on the boundary cables from the main cables were used to define a more correct boundary cable without a change of length. Using this boundary cable profile and the two extreme cables of the roof (e.g. both edge cables or the ridge cable and side cable), the specially written program DATCAB was run to establish an input data for the Brotton stiffness program FINDEF. The two defining edge cables were subdivided and connected with the generators. The remaining cables were defined by interpolation along the generators which therefore had no moment. This input



**Fig. 8**  
Plan of Hirst's Amphitheatre

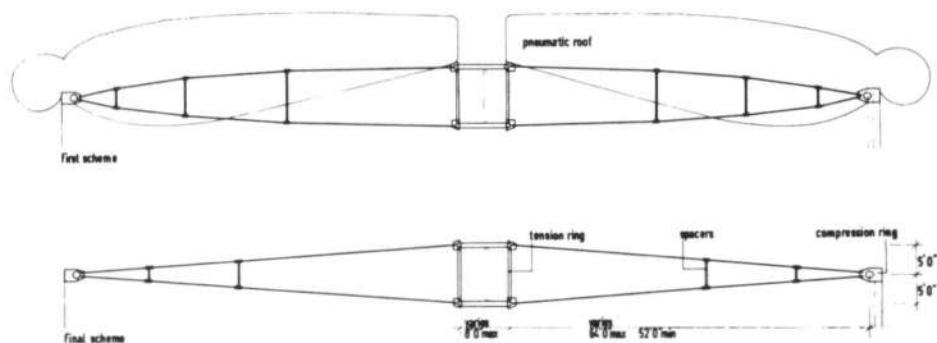

**Fig. 9**  
Sections through Hirst's Amphitheatre

was then run on the FINDEF program and the geometry under load was found. On the early runs the answer from the FINDEF run differed considerably from the input geometry. In particular the boundary cable moved considerably. Therefore the output of the FINDEF program was used to give a new set of boundary cable forces and the boundary cable was re-calculated on CABNET. The cycle had started again (See Fig. 3). The iterative process was considered finished when the difference between the deflected shape of the boundary cable on the CABNET run and the FINDEF run was no more than 5 mm in the direction of the main cables and 20 mm normal to the main cables. Once this was done, the roof was checked structurally on FINDEF for all likely load conditions.

Four quite separate but similar geometries were defined in this way. One has been built and three others should be erected in July.

#### Mecca Kafess structure

Kafess is an Arabic word for a timber lattice. In this case it will be used to provide shade to an internal courtyard. The kafess structure is a free form radial system of prestressed cable trusses which are supported from a central boundary cable and connected to a building at the outer boundary.

The boundary cable and the points at which the radial planes start had to be defined accurately. The radial planes, which differed from each other, had to be formed to deter-

mine the necessary prestress and to build up a picture of the prestressed condition.

For initial design purposes a simple model was created for a radial cable pair. In the following,  $f$  is the sag and  $l$  the length between support points and  $T_u$  and  $T_l$  are the horizontal components of the tension in the upper and lower cables respectively and  $T_s$  the sum of  $T_u$  and  $T_l$ .

For uniform load a small deflection theory gives a linear relationship between the cable tensions and applied external load  $w$  for any sag ratio  $f_u/f_l$ . This can be expressed graphically as shown in the prestress diagram (Fig. 6). The results of the linear analysis were tested on the computer using the three dimensional cable program CABNET for a range of profile shapes. The deviations from the linear prestress diagram were small.

Using the general architectural considerations for surface continuity and the need to keep all the cables the same size, the ratio of cable sags  $f_u/f_l$  was chosen and from that the approximate cable profiles were calculated. As with the main auditorium the boundary cable support points had to be assumed. Using the level of prestress required in the most highly stressed radial pair, the horizontal profile of the boundary cable was checked by hand and the level of prestress on each radial pair was found. Where this was excessive or when the boundary cable tension was excessive, the boundary cable profile was ad-



justed. This adjustment changed the force balance and hence the prestress level of the radial pairs. When an acceptable balance had been found, the horizontal profile of the boundary cable was checked on the computer (CABNET) with the radial pairs included as springs. Once the horizontal profile was fixed, the vertical profile was checked, by finding the vertical loads on the boundary cable from the basic geometries defined earlier. A simple funicular polygon sufficed to give a good idea of the vertical profile of the boundary cable, as the horizontal component of the tension was known. The whole boundary cable, under its full loads, was then checked on CABNET. The new positions of the inside end of the radial pairs were used when the radial pairs were redefined (using the same ratio  $f_u/f_i$ ). The new forces were fed into a new boundary cable run. Two iterations of the computer part of the sequence were usually sufficient to get good agreement for the boundary cable shape.

One sample computer check on a modified whole kafess structure (using reduced number of radial pairs) was carried out and gave satisfactory results. The iterative system is set out in Fig. 7.

### Hirst's Amphitheatre

Shortly after the design of the Mecca kafess structure had been completed, another design opportunity arose in which the general experience developed there was put to use. A site in the centre of London had been chosen for a temporary theatre required for three months during the winter. The theatre had to be re-usable. This site, which was irregular in shape, was surrounded by grass and it was a condition of the lease that the construction company should not damage the grass. An existing band-stand at one end acted as a stage. Maximum site use was required. As the building was to be used as a circus, it had a natural centre which dictated the seating plan. The solution was generated by the planning and it is shown on Fig. 8 superimposed on a site plan. It has vertical walls, 13 m high and a prestressed ring structure. The roofing is made of large pneumatic air bags suspended between the vertical planes of the prestressed cables and spilling out over the edges. Initially the design of the walls and ring was seen as a number of similar shear panel segments pinned together, with a pinned compression ring at the top. This was stabilized by the spring support of the cable planes, which, once they are tensioned, act in both tension and compression.

The curvature of both the top and bottom cable was chosen equal, so that under small deflection theory the effective tension applied to the outside compression ring did not change (See Fig. 6). It can be seen from the geometry that an artificial centre node has been chosen for the ring. The angle subtended at the boundary is the same for all the circular elements. The large angles are approximately equal to three times the smaller angles. Thus all trusses were from the same size rope, the corner trusses being simply three standard trusses. It was anticipated that the changes in tension applied at the ring which would result from the deflection, would be accommodated by small changes in the ring profile under use. These small changes would most likely arise due to tolerance errors in the manufacture of the rope or the ring, as well as unsymmetrical load.

Under wind load the ring acted as a horizontal frame rather like a bicycle wheel, transferring load to the vertical shear panels. The relative size of these wind forces was small compared to the net prestress forces (maximum 25 kN compared with a total average prestress force for the top and bottom cables of 300 kN). Full snow load of 720 N/m<sup>2</sup> and a wind uplift of 740 N/m<sup>2</sup> were used in the design. The first estimate of a design geometry is shown in Fig. 9.

When these first designs were checked on the computer, the vertical deflection was discovered to be about 300 mm under the maximum wind or snow load. This caused an increase in total horizontal tension from 29.5 tons to 38.4 tons or approximately 30%. It was apparent that the deflections were large and that the small deflection theory expressed in the prestress diagram was not working too well. Furthermore, the assumption that the ring was a pinned system was proving difficult to substantiate at a detailed level: pins are notoriously expensive and difficult to design and manufacture. It also became apparent that a system of erection where the ring was tensioned at ground level would be much easier to handle than one where the tensioning was done in the air. This was particularly true as it was intended to re-use the building on a number of sites in the summer. This led to the concept that inside the frame there should be a continuous compression ring which could be pre-tensioned and lifted into position, with deflated airbags placed on it. Early design checks of this system, to determine the overall stability of the truss, particularly during lifting, were done using a simplified truss (See Fig. 9). It was obvious that this straight system was ideal for easy erection and the early indications showed that it did not deflect much more than the previous geometry. Detailed checks on the computer using the non-linear cable programs showed that the additional tension induced at the ring because of the straight cables was only from 29.5 tons under no load to 42.3 tons under full load, compared with 29.5 tons to 38.4 tons. This was, of course, helped a great deal by the fact that rope with a low Young's Modulus was being used. A simple analysis was then carried out to find the minimum number of vertical members and their disposition. The local effect of applying load to the straight prestressed cables was accommodated by the ability of the system to strain sufficiently to develop a curvature to resist the loads. The stressing assumed that the ropes would be just taut in the horizontal position when the drum height was zero. Once this system had been defined, the effect of tolerance errors and stressing inaccuracies was easy to account for. At the time of writing, this structure has been manufactured (including the pneumatic section) but has not been used for financial reasons. There are hopes that it will be used in the near future.

### Relative stiffnesses or rope versus strand

The correct choice between rope and strand is often clouded by the simple issues. Strand can be up to 30% cheaper than rope for the same load carried. Strand is light and, in the smaller diameters, easy to handle. It is stable and predictable in performance and its elastic modulus  $E$  is well known. It is stiffer than rope and therefore deflects less. But is this what is wanted? Being stiffer, it also extends less and in a prestressed structure this means a much greater emphasis on accurate specification and manufacture of the cables and a much greater range of prestress if any errors occur. Being stiffer it deflects less and this means that the benefits of non-linearity are less. A structure where the load carrying capacity has been defined on static geometry has a large additional reserve of strength from its non-linearity (perhaps 20–30% before prestress is lost). But the biggest disadvantage comes from its bending stiffness. All but the smallest spiral steel strands have a substantial bending stiffness. This is most awkward when handling the cable and if mishandled one often finds wires buckle out. This bending stiffness can also cause local overstressing under clamping forces. The exact bending which exists is difficult to calculate and the only guide known to me is given in Wyatt's paper<sup>4</sup>. Altogether great care has to be taken to ensure that the

minimum radius of curvature of large diameter steel strands is carefully controlled. The last factor is that ropes are much easier to grip, either as end sockets or swages or in clamps. This is discussed below.

In spite of this, there are occasions when one can legitimately prefer strand to rope. Whereas I would always prefer rope to strand for prestressed systems and for all boundary cables, there is probably no need to use rope for single curvature heavyweight cable roofs. Here the deflection in response to load is largely geometric and the effect of cable strain is less important.

### Tolerances

For tolerances one might read erection problems, because for completely prefabricated cable structures the two are almost synonymous. As with any discussion on tolerances, prejudice plays a large part. My central belief is that no allowance should be made for adjustment except at points where the cable system is joined to concrete. Thus on the Mecca heavyweight main roof no adjustment is allowed on the cable to boundary cable connection or at the masts, or the main beam. It is therefore very important that the cables are accurately manufactured and specified. The rationale for this decision is that small errors could create havoc while erecting a roof and it would be extremely difficult to define a base against which to assess errors. The size of tolerable error can, of course, be defined. It is related to the overall elastic extension of the cables under load. As an example, if the cables on Mecca had an extension under working load of approximately 60 mm then 50 mm extra length would cause overloading in other cables. Conversely a short cable would attract a high load. In general, it is probably true that occasional errors of up to 40% of the working extension are acceptable. This is usually achievable in practice. This has been checked on a specially constructed trial erection structure erected at Tours, France, which was also used to train personnel who can enter Mecca. Errors of perhaps 25% can also be accepted in prestressed systems, though there will be some distortion of the surface when errors occur. These errors do not affect the ultimate capacity of the roof. Overall errors do not much affect heavyweight roofs, but they can have a big effect on prestressed systems.

An alternative solution, adopted for the Mecca kafess structure where all the cables are connected at one end to the surrounding concrete structure, is to use adjustable friction fittings. These are there to counteract concrete errors. The philosophy of this choice is somewhat tortuous but real for all that. It was to make the fittings adjustable but difficult to use, thus placing a positive emphasis on accurate fabrication.

### Design of fittings

Fittings are the attachments which grip cables either at the end or along their length. They can be classified by the method used to grip the cable. Three kinds are in common use in cable roofs: cast zinc sockets which are always end fittings; pressed or swaged fittings; and friction fittings which clamp on the cable. Each is appropriate in different circumstances. Cast zinc sockets are used on large rope and on strand. Pressed fittings are used as end fittings on smaller ropes. Friction fittings are usual for intermediate fittings on a cable, either strand or rope. Sockets and pressed fittings are supplied with the cable and are normally fully tested and guaranteed by the manufacturer. As such, the choice between them is not a problem and the only comparative comment that can be made is that one imagines pressed fittings would be better in fire. However, there is no direct evidence on this and very little evidence on the fire resistance of fittings generally. The design problems arise with friction fittings.

The central problem with friction fittings is the choice of a co-efficient of friction. The co-efficient of friction determines the clamping force and hence the size of the clamp. (Certain people feel that the length of clamp also affects the co-efficient of friction but this is not well documented). Recently a series of tests was made on friction fittings, giving quite different results. In each test the cables were galvanized. The three tests were:

- (a) A cast and galvanized intermediate clamp 200 mm long on a 60 mm spiral steel strand with a clamping force of 200 tons. The co-efficient of sliding friction was 0.10.
- (b) The same clamp ungalvanized with the same force and strand. The co-efficient of sliding friction was 0.23.
- (c) A 150 mm galvanized end clamp on a 16 mm rope with a clamping force of 44 tons. The co-efficient of sliding friction was 0.3 and that for sustained friction was 0.28.

In each case the co-efficient of friction was measured against the nett compression on the cable without any effect of tension bending in the clamp (i.e. twice the bolt tension). Bending curvature was not considered likely. In the case of the rope clamp, the result was the same whether the cable was wholly inside the clamp or sticking out the other side. These results indicate the wide range of results that can occur and are indicative of the care that must be taken.

It is not, however, easy to define the effective compression on the clamp in use. This is particularly true of intermediate clamps. The tests described above were done when there was no tension in the supporting cable. As the supporting cable is tensioned, the diameter will decrease (how much is not known). The resultant diameter decrease will represent a loss of strain in the clamping bolts. Many people, including most manufacturers, recommend using long high tensile bolts to counteract this. However, high tensile bolts, particularly if cadmium plated, are prone to failure and are less able to accept distortions in the clamp than ordinary mild steel bolts. Professor Otto is on record as preferring mild steel bolts. These can be re-tightened after the initial strain in the boundary cable to counteract the cable reduction.

### Conclusions

The conclusions are simple, that is if conclusions, other than a built design, can be said to exist for the designer. Cable structures are flexible. Their true strength lies in their ability to absorb large distortions. They should be conceived and designed as flexible systems, with materials and parts carefully chosen. In specification, manufacture and erection they are akin to precast concrete. Accurate design and specification and control at the manufacturing stage are essential for simple erection. The need for accurate specification need not hinder adventurous design. Perhaps if this reality were accepted, cable systems would be less expensive, less frightening for the contractor and they could take their rightful place in the designer's catalogue.

### References

- (1) Frei Otto at Work. *Architectural Design*, 47, pp. 137-167, March 1971.
- (2) BUCHHOLDT, H. A. and others. The analysis of cable nets. *Journal of the Institute of Mathematics and its applications*, 4, pp. 339-358, December 1968.
- (3) BROOKS, D. F. and BROTTON, D. M. Formulation of a general space frame programme for a large computer. *Structural Engineer*, 44 (11), pp. 381-396, November 1966.
- (4) WYATT, T. A. Secondary stresses in parallel wire suspension cables. *ASCE Proceedings: Journal of the Structural Division*, 10 86 (ST 7), pp. 37-59, July 1960.

# Stressed rock-anchor antenna-support towers

Bob Kelman and Harry Holmes\*

### Introduction

At the time of its inception in 1964, the East-West route linking Port Pirie in South Australia with Northam, 80 miles north-east of Perth (job no. A165), was the longest microwave route yet considered.

Of the total route length of 2250 km, the central section crossed 1100 km of barren, featureless plain, virtually devoid of any services, with summer temperatures reaching 50°C, and with no recognized sources of water. Supply of materials, maintenance of equipment and adequate accommodation for men over a period of a year, presented formidable problems. The normal gravity type of foundation for a 75 m tower contained nearly 80 m<sup>3</sup> of concrete for each leg, and it was obvious that any design which could reduce excavation and concrete quantities was desirable. Furthermore, little knowledge of local geology existed and there were few known sources of supply of concrete materials. Such were the considerations that led to the development of stressed rock-anchor foundations.

### Site investigation

At the time of tendering, only the sites for the end sections of the route were firmly established. Provisional sites existed for the central section. A site investigation was carried out by George Wimpey and Co. Ltd. during which test bores for soil investigation were carried out at all accessible established sites, and the central section of the route sampled by drilling approximately every fifth provisional site. The results were encouraging and indicated three zones with transition areas in between.

- (a) Western Australia (Northam to Kalgoorlie)—generally a sandy soil over decomposed granite
- (b) Central Nullarbor region—Nullarbor limestones, porous and very variable and likely to contain cavities of considerable size
- (c) South Australia (Ceduna to Whyalla)—hard igneous rock often close to, or at the surface

### Design

The design of rock-anchor foundation had to satisfy certain requirements. It had to provide:

- (1) adequate anchorage against uplift forces
- (2) adequate resistance to downward forces
- (3) adequate stability against sliding or overturning under combinations of vertical and horizontal forces and
- (4) adequate factor of safety against overload and long term corrosion.

In principle it is simple. The tower leg base plate (Fig. 1) is directly connected to the stressing anchorage plate through the holding down bolts. Uplift forces are conveyed to the anchorage zone at the lower end of the pile. Under no-load conditions, the stressing forces are restrained by the bearing of the footing on the soil or rock. Not until the tower uplift forces exceed the residual stress is there any tendency for the footing to lift.

The disadvantage is that the downward load on any footing is doubled, as it must resist the stressing force together with the maximum downward tower leg force. Thus a foundation bearing value of about 6.4 MN/m<sup>2</sup> was considered essential if the stressed footings were to be much smaller than gravity footings. On sound igneous rock, the stressed footing pad was just sufficient to accommodate base

plate, anchorage and bolts. Towers varied in height from 23-76 m. Uplift forces varied from 52,000 to 104,000 kg. For the purpose of design, two types of footing were developed, one for towers from 23 m to 46 m and the other for 53 m to 76 m.

Various prestressing systems were examined and the *Freyssinet* System was chosen. It proved most easily adaptable to the design and offered cable capacities most suited to the range of forces required. Anchorage forces available from the ground were assumed to be the weight of a 60° inverted cone with its vertex at the anchorage depth (Fig. 2). No advantage was taken of soil cohesion, internal friction or tensile strength in soil or rock. A factor of safety was taken at 1.6 for the weight of the soil cone over uplift forces exerted by the tower under design wind speed of 160 km/h.

To ensure that the stressing force was restrained between the footing bearing on the ground and the pile anchored at its lower extremity, a slip joint was provided through the depth of the footing. If this were omitted, the risk would exist of the pile resisting the stressing force as a column in compression, and the stressing operation, designed to load test the pile anchorage for each foundation, would give no indication of pile slip.

### Development

A test programme, prior to any field construction, was designed to perfect and prove each phase of the operation and to establish safe values for bond between cable and grout and between concrete and rock.

The basic problem to be overcome was the means of placing and anchoring cables 9 m down in the ground, with efficient protection from corrosion over a long period. It was suspected that ground water, if present, could be high in sulphates and chlorides, and the Nullarbor limestones were known to be porous. It was not considered that sufficient corrosion protection could be given to cables if these were simply grouted into a bored hole. It was therefore decided to cast a concrete pile in the ground, with a central 100 mm duct for the cables. Minimum pile diameter was considered to be 230 mm. Equipment selected for boring the 230 mm pile hole was the Ingersoll-Rand rotary percussion 'Down the Hole' hammer used in conjunction with a Pioneer rotary drill and compressors.

After several attempts at 'casting in' the 100 mm duct, it was successfully achieved by casting a solid pile with a concentric cage of reinforcement and then drilling a 100 mm duct down the centre. The reinforcement cage acted as a guide to the drill. Three full scale foundations were constructed and a routine established for setting out, drilling, concreting, grouting and stressing.

The experience gained during the test programme, itself the result of collaboration between Arups and the contractors, Electric Power Transmission Pty Ltd. (EPT), was incorporated in the final design. EPT were able to go into the field with a new form of construction with which they were already experienced, with the result that field procedure generally ran smoothly and efficiently.

### Construction

Field work commenced at Whyalla in November 1967 and at the western end of the route in February 1968.

Each gang was fully equipped to construct both stressed and mass type of foundations, although only two mass types were constructed in the west. Each gang was accompanied by a resident engineer and Clerk of Works provided by Arups.

Conditions along the route had improved considerably since the time of tendering. The road over the Nullarbor Plain was carrying much more traffic and, from the West Australian border to Perth, was substantially sealed.

although the South Australian section had 650 km of deeply pot-holed roads. However, the logistics of construction remained formidable. Concrete aggregates were carried from Ceduna and Kalgoorlie with a maximum distance between source and site of 800 km. Water was carried in 11,000 litre collapsible rubber tanks up to 650 km from Norseman and Ceduna. Cement was brought up to 1600 km by road from Adelaide and Perth.

It was necessary to maintain a stable and skilled labour force in this isolated area for more than a year when even daily variations in climate were from 50°C with wind and dust, to cold, wet winds from the Antarctic Ocean. EPT decided to use completely mobile air-conditioned camps to be towed by construction vehicles from site to site. The standard complex consisted of a 13 m messing and kitchen unit, a 6.7 m bathroom and toilet unit with pressurized hot water, a 6.7 m office and and foreman's accommodation and two 6.7 m sleeping units. Electric power was provided by a 75 kw generator. Such camps accommodated up to 17 men.

As far as was possible, construction followed an eight day cycle, six or seven days work and a day moving camp to the next site. Stressing was carried out after one week and the restressing check and final grouting a week later again. Planning allowed for a second stressing operation should the restress check indicate a loss of prestress to below 60% of the cable capacity.

Once camp was established on site, work proceeded approximately to the following sequence:

- Day 1 Survey, setting out, excavation
- Day 2 Position pipe sleeve, bolts and reinforcement
- Day 3 Place concrete
- Day 4 Drill pile hole through pipe sleeve, place reinforcement cage and concrete pile
- Day 5 Drill 100 mm duct in pile, place tendons and grout the lowest 3 m anchorage zone

With four bases to each tower, these operations tended to overlap a couple of days. Concurrently, the foundations for equipment shelters, waveguide bases and wind-generator towers were constructed.

On sites incorporating mass concrete bases some 300 m<sup>3</sup> of excavation was required and the construction extended to 12 or 14 days.

#### Pile failure

South Australian sites gave few problems. Conditions were either dense igneous rock or deep sand. The type of foundation was clearly indicated and construction was straightforward.

In the west, the weathered granite proved to be extremely variable, from almost sound rock to material from which most of the feldspars had weathered away to a kaolinized grit.

At the foundation level of the footing pads this material was firm and non-compressible, but tended to abrade easily. The percussion drill penetrated it rapidly and the drillings were ejected as fine talc-like powder.

When the foundation first constructed at Bulgin Rock (Site number 2) was stressed, cable extensions apparently exceeded calculated elongations, and a careful check showed that the pile was in fact moving upwards through the slip joint in the footing. There was no alternative to extracting the piles and reconstructing the foundation to give more effective anchorage.

This was done with the prestressing jacks, but as these had a stroke of only about 500 mm, the pile had to be broken up with jack hammers each time the jacks reached their limit. The procedure was slow, laborious and risky, because a broken cable would have

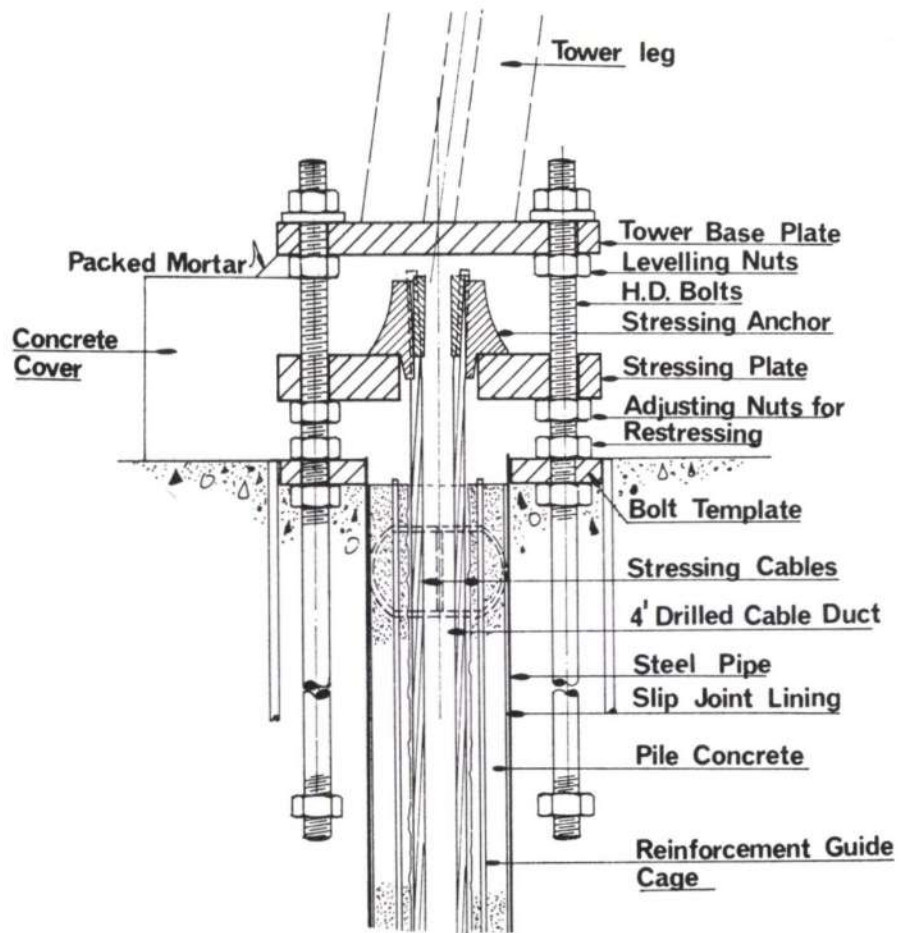

**Fig. 1**  
Connection to tower leg

eliminated the means of removal and necessitated complete reconstruction of the site. Means were then considered of ensuring against further pile slip. A bulb at the base of the pile seemed the obvious answer. Discussions with an explosives expert in the New South Wales Department of Mines raised hopes, and on his advice, a bundle of 21 sticks of gelignite was detonated at the base of a deepened hole. Apparatus was developed to plot the size of the cavity produced and this proved to be from 500 to 600 mm diameter and from 1.2 to 1.5 m in height.

The foundation was reconstructed and restressed. On the first application and release of the load there was an upward yield of approximately 9.5 mm. This was not repeated on restressing and no creep or loss of stress was evident on restressing after seven days, even though the second and third holes had been detonated while the stress was held on the first.

It is interesting to record that this site was the most closely situated to the centre of the earthquake which demolished the village of Meckering in 1968. There was evidence that considerable ground movement had taken place at the tower, but no evidence of damage.

The lessons learnt at this site were put to good use later on. At all sites where rock appeared weathered, friable or soft, the hole depth was increased and a charge fired in the base to provide a bulb. Early difficulties in checking the size of the bulb were overcome by the simple expedient of lowering a light on a flex and swinging this across the hole. The period of darkness as the light went beyond the limits of the shaft gave a clear indication of the size of the bulb formed.

This experience all proved extremely valuable once construction had moved into the Nullarbor limestone and allowed the use of stressed foundations continuously from sites 3 to 33.

#### Cavities in limestone

Initial geological advice had emphasized the presence of cavities in the Nullarbor limestone. These could be vast, extending many tens of metres horizontally and vertically. The existence of such large ones was generally known, but smaller ones, from 1.5 to 6 m deep, constituted a real problem, and various techniques of sleeving the pile through these had been considered. In practice only one, at site 27, was encountered, about 2.5 m deep and it rapidly filled when the pile was concreted.

No other serious problems were encountered, although the design of each foundation had to be confirmed, and often modified by the resident engineer on site, to accommodate the bearing capacity available and the depth of excavation necessary to achieve this, when these varied from the design assumptions shown on the drawings.

#### Tower design

Full calculations of a basic tower structure to support four to six reflectors were required by the specification. The towers were to resist a wind velocity of 160 km/h at ground level, increasing with height, the design code being in accordance with a Post Office document, and which would result in a factor of safety on ultimate structure strength in the order of 1.5-1.7. The design used a common geometry for four- and six-reflector towers and is very similar to that commonly used by the Post Office throughout Australia. All of this resulted in structures with standardized members which could be mass produced in an economical manner.

Reflectors were considered to be at two or three levels at the top of the tower, but route design required widely different levels, particularly for diversity reflectors. EPT proposed that reflector mounting positions should be established at 12 distinct heights. It was

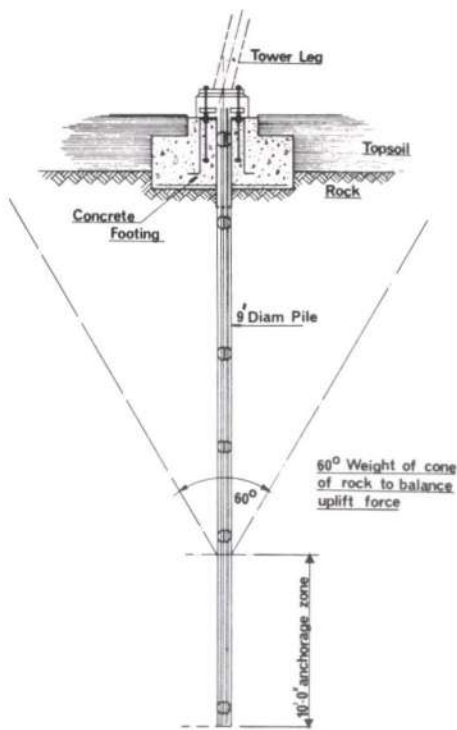

**Fig. 2**  
Anchor footing, general detail

**Fig. 3 right**  
A completed tower

agreed that these levels would be adequate to achieve the route performance required and also facilitate any late changes in reflector levels indicated by propagation tests.

At each level, platform steelwork was designed to suit the face or faces on which reflectors were to be mounted. These platforms connected with the tower access ladder which had full rest platforms at a maximum spacing of 15 m. All tower bracing was proportioned to resist shear forces which would result from reflectors at any level, independently of the actual usage.

#### Waveguide runs

The type of waveguide used on this system, 145 mm x 68 mm elliptical, although flexible, placed considerable constraints on tower arrangements. On its H-plane axis the waveguide has a bending radius of 1.55 m, which is significant compared with the total tower width of 2.4 m at the top of the structure. Moreover, each antenna had a specified polarization which determined which axis of the ellipse was horizontal.

The vertical waveguide runway was placed on the outside of the tower. This reduced difficulties in hauling the waveguide off the drums compared to that which would have been experienced with the normal waveguide run inside the structure. It also made the full tower width available for bends. Although the heights of many reflectors were known at the time of detailing steelwork, their polarization was not and waveguide bends could not be predetermined to establish the position of a reflector on the pair of horizontal mounting bars used to support it. It was therefore decided that mounting bars should be provided with holes to permit reflectors to be mounted at positions variable in 50 mm steps across the tower face.

Finally, it was necessary to design ancillary supporting steelwork for a horizontal waveguide gantry between the tower and the shelters and to support the final bends in the waveguide to the reflectors at 1 m maximum spacing. The former was standardized into a

few simple component structures, but the latter had extensive provision for adjustment on site.

#### Erection

Two tower erection crews were employed, each with mobile camping arrangements as for the foundation crews. Erection of steelwork to approximately 45 m height was done with a 27 ton mobile crane, having a total jib length of 49 m. Above this height, erection was done with an aluminium floating jib. The average erection time for a 76 m tower was six days.

#### Conclusion

Notwithstanding the decision to adopt a completely new type of foundation requiring extensive preliminary development, all tower structures were finally erected within the intended time. By approaching the formidable problems of logistics and establishment in this difficult area in a proper manner, it was demonstrated that modern techniques could be employed on both foundations and tower structures with very favourable results.



On technical grounds, there is no doubt that the departure from the type of foundation traditionally accepted for towers has proved to be successful. It is effective, simple and quick to construct, adaptable to varied site conditions (subject only to certain overriding requirements) and lends itself to the efficient organization of site labour, in that tower erection and foundation work can be done quite separately by specialist gangs.

The end result is that the rock-anchor form of construction can give a considerable saving in both money and time over the traditional mass-footing method. Geological survey information is essential to establish that sufficient number of the prestressed foundations can be constructed to justify the cost of mobilization of the specialized equipment required. In this case, the original assessment was that 48 out of the 58 sites would be suitable. In fact only 40 proved to be so, although the experience subsequently gained indicates that at least some of the eight might have been stressed foundations. It was particularly disadvantageous that the majority of these eight sites were in the most remote areas where the saving of transport costs for the great quantities of material for the mass footings would have given the stressed footings their greatest savings.

As a result of the standardized tower design erection costs, placing heavy emphasis on mechanical equipment, produced results which compared very favourably with those achieved in erecting similar structures in much more hospitable locations.

#### Appendix Design stresses

Concrete	20.7 N/mm <sup>2</sup> in bases. 27.6 N/mm <sup>2</sup> in piles.
Grout	17.2 N/mm <sup>2</sup> .
Cables	At design working loads equivalent to 44.7 m/s wind speed: 60% minimum guaranteed ultimate tensile strength.

Bond stress—Design loads	
Cables	0.97 N/mm <sup>2</sup>
Concrete to rock	0.76 N/mm <sup>2</sup>
Stressing values	
Initial stress	=85%
ultimate strength of cables	
Check restess	=75%
ultimate strength of cables	
Minimum residual stress	=60%
ultimate strength of cables: and is the minimum permanent stress and thus equals the design wind load uplift for the tower, increased by a factor which depended on the overturning moment at the base. Due to the fact that cables were used in groups of 6, 8, 10 or 12, these increments did not exactly match the uplift forces for different tower heights and there was frequently an excess of cable capacity in the smaller towers.	

Thus minimum ultimate load factor=1.67.

*\*This article originally appeared in The Telecommunication Journal of Australia. Bob Kelman works in our Sydney office: Harry Holmes is employed by Electric Power Transmissions, Pty., Ltd.*

# The calculation of earth pressure in open cuts in soft clays

David Henkel

## Introduction

The weight of the soil on either side of an open cut acts as a surcharge on the ground at the level of the base of the excavation. In clays the maximum possible depth of the excavation, even if the strutting is adequate, is limited by base failure when the bottom of the cut heaves up into the excavation.

Bjerrum and Eide<sup>1</sup> showed that base failure could be predicted with reasonable accuracy by treating the situation as the inverse of the normal foundation bearing capacity problem using the bearing capacity factors proposed by Skempton<sup>2</sup>. These factors, which depend on the geometry of the excavation, vary between about 6 and 8 for normal excavations. The critical depth of excavation,  $H_c$ , at which base failure will take place may be expressed as:

$$H_c = \frac{c_b N_c}{\gamma}$$

where  $c_b$  is the undrained strength of the clay beneath the excavation floor

$N_c$  is the bearing capacity factor

and  $\gamma$  is the bulk density of the soil in which the excavation is made.

An index of the extent to which the excavation is approaching base failure is given by the dimensionless number

$$N = \frac{\gamma H}{c_b}$$

which cannot exceed  $N_c$  or collapse will take place. As  $N$  increases above about 5, significant plastic deformations develop below the base of the excavation and experience has shown that the force  $P_a$ , due to earth pressures that have to be carried by the strutting system, becomes much greater than those computed by the normal procedures using Bell's equation

$$\text{viz. } P_a = \frac{1}{2} \gamma H^2 - 2cH$$

where  $c$  is the undrained strength of the clay behind the face of the excavation.

The published methods for handling this problem are empirical (Flaate<sup>3</sup>; Terzaghi and Peck<sup>4</sup>). In his General Report to the Mexico City Conference, Peck<sup>5</sup> suggested that, as an expedient, pending the development of the appropriate theoretical treatment, a reduced value of the shear strength of the clay behind the wall should be used in Bell's equation namely

$$P_a = \frac{1}{2} \gamma H^2 - 2m c H$$

where

$$m < 1$$

For the two groups of field observations available Peck found that a value of  $m$  of 0.4 gave agreement with the field measurements for the sites in question in Oslo and Mexico City.

In order to provide a more satisfactory method of handling this problem the writer has de-

veloped the theoretical treatment described below.

## Theoretical treatment

The theoretical treatment is based on the development of plastic Prandtl zones beneath the floor of the excavation and is illustrated in Fig. 1 for a long excavation of depth  $H$  and width  $B$ . Where bedrock is at a distance greater than  $B/\sqrt{2}$  below the base of the excavation, the whole of the excavation width is involved in the plastic zone, as shown in Fig. 1.

If, however, the bedrock surface is closer than  $B/\sqrt{2}$ , the dimensions of the plastic zone are controlled by the distance,  $d$ , from the base of the excavation to bedrock as shown in Fig. 2.

The potential failure mechanism involves the sliding of the mass of soil above the base of the excavation on a plane inclined at  $45^\circ$  to the horizontal and this sliding plane merges with the Prandtl zone beneath the base of the excavation as shown in Fig. 1.

The total force  $P_a$  required to prevent the material from sliding with this mechanism may be found from the principle of virtual work.

The kinematics require that if the vertical movement of the soil mass above the base of the excavation is  $\delta$ , the movement on the sliding surface is  $\delta\sqrt{2}$  and  $P_a$  is pushed back by  $\delta$ . The work done in the system may be written as follows:

$$W\delta = P_a\delta + H\sqrt{2} \cdot \delta\sqrt{2} \cdot c + (2d \cdot \delta\sqrt{2} + \pi d \cdot \delta\sqrt{2}) c_b \text{ where}$$

$W$  is the weight of the sliding soil mass above the base of the excavation

$c$  is the undrained shear strength of the clay above the base of the excavation

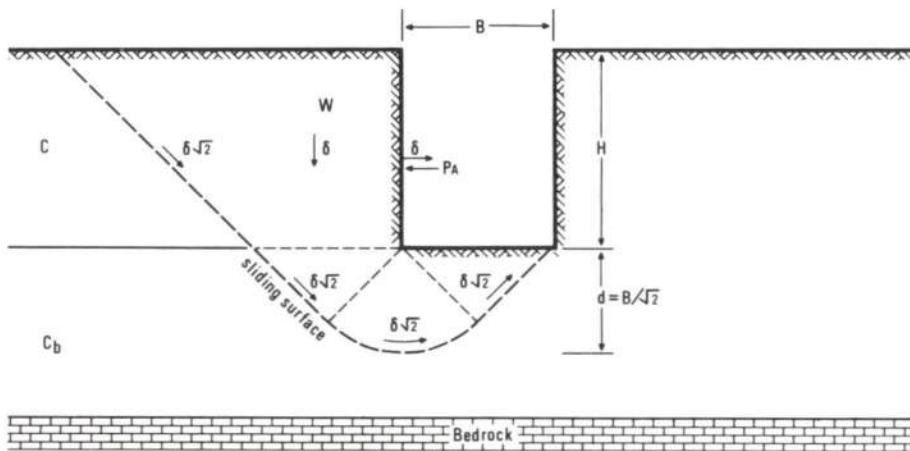

Fig. 1 Proposed failure mechanism

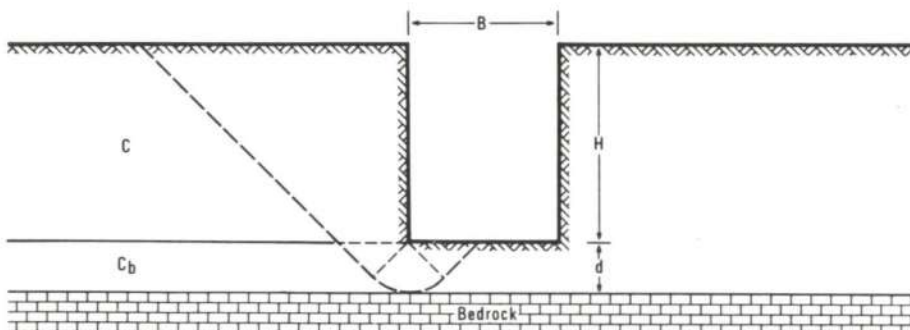
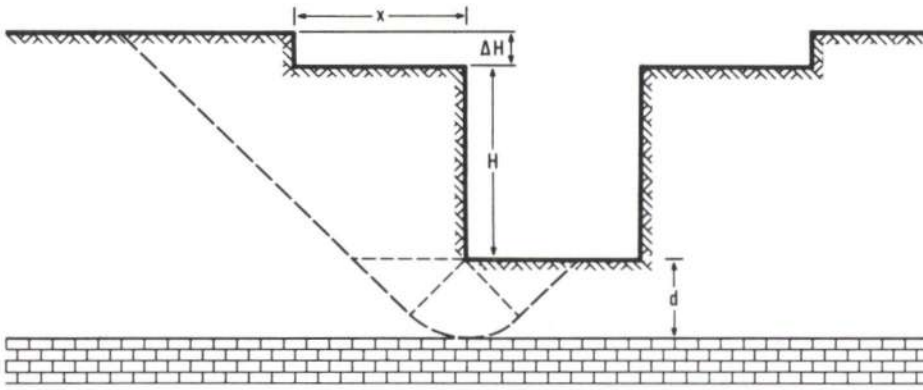

Fig. 2 Failure mechanism limited in depth by a layer of bed-rock



**Fig. 3**  
Unloading adjacent to excavation

$c_b$  is the undrained shear strength of the clay below the base of the excavation.

Now

$$W = (Hd\sqrt{2} + \frac{1}{2}H^2) \gamma$$

where  $\gamma$  is the density of the soil above the base of the foundation excavation and

$$P_a = \left( \frac{1}{2}\gamma H^2 - 2c \cdot H \right) + d\sqrt{2} \left( \gamma H - (2 + \pi) c_b \right)$$

or following Terzaghi and Peck

$$K_a = \frac{P_a}{\frac{1}{2}\gamma H^2} = \left( 1 - \frac{4c}{\gamma H} \right) + \frac{2\sqrt{2} \cdot d}{H} \left( 1 - \frac{(2 + \pi) c_b}{\gamma H} \right) \quad (1)$$

The term  $(1 - (4c/\gamma H))$  represents the conventional value of  $K_a$  from Bell's equation. The second term, which must be positive, indicates that when  $(\gamma H/c_b) > 5.14$  there will be an added component of earth pressure,  $\Delta K_a$ .

The value of  $d$  to be used in the calculations will depend on the local stratigraphy. If the depth of the Prandtl zone is limited by a strong stratum, as shown in Fig. 2, the appropriate value of  $d$  will be the depth of the strong stratum below the bottom of the excavation.

The inclusion of the plastic zone below the excavation into the deformation mechanism indicates that ground movements are likely to extend to a much greater distance from the edges of the excavation than would be expected if only movement above the base of the excavation is included.

In some excavations, local unloading adjacent to the cut has been carried out, but to be completely effective in reducing the apparent depth of cut, the local unloading will have to go much further than the distance of about  $H$  which is normal practice. This case is considered in Fig. 3. The appropriate equation for  $K_a$  may be developed as before and is

$$K_a = \left( 1 - \frac{4c}{\gamma H} \right) + \frac{2d\sqrt{2}}{H} \left[ 1 + \frac{\Delta H}{H} \left( 1 + \frac{H + (\Delta H/2) - x}{d\sqrt{2}} \right) - \frac{c_b}{\gamma H} \times \left( 5.14 + \frac{2c}{c_b} \cdot \frac{\Delta H}{d\sqrt{2}} \right) \right] \quad (2)$$

The second term may not be negative and  $x$  cannot be greater than  $d\sqrt{2} + H + (\Delta H/2)$ . In order to illustrate the magnitude of the effect

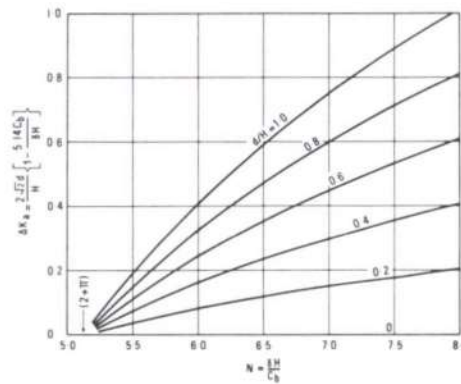

**Fig. 4**  
Variation of  $\Delta K_a$  with  $N$  and  $(d/H)$

**Table 1**

Site	$d$ m	$H$ m	$\Delta H$ m	$x$ m	$\gamma$ tonnes $m^{-3}$	$c$ tonnes $m^{-2}$	$c_b$ tonnes $m^{-2}$	measured	$K_a$ calc. (A)*	calc. (B)*
Vaterland 1	5.2	10.4	—	—	1.89	2.6	2.7	0.88	0.89	0.47
Vaterland 2	6.4	10.7	—	—	1.89	2.6	2.5	1.12	1.06	0.49
Vaterland 3	8.1	9.2	2.8	9.4	1.90	2.9	3.5	0.92	0.90	0.34
Mexico City	5.0	9.0	2.3	11.0	1.22	2.1	1.6	0.66 -0.80	0.79	0.23

\*A Proposed new method  
\*B Bell's equation

of plastic zones developing below the excavation flow, the values of the second term in equation (1)

i.e.

$$\frac{2d\sqrt{2}}{H} \left[ 1 - \frac{(2 + \pi) c_b}{\gamma H} \right]$$

which represents  $\Delta K_a$ , or the increase over the value found from Bell's equation, have been evaluated and are plotted in Fig. 4. The range covered is for  $(\gamma H/c_b)$  from 5.14 to 8.0 and for  $(d/H)$  from 0 to 1. It will be seen that for the higher values of  $(\gamma H/c_b)$  and  $(d/H)$  the value of  $\Delta K_a$  becomes very significant.

**Application**

Three of the instrumental sections on the Oslo Subway, known as Vaterland 1, 2 & 3 were located in areas where the values of  $(\gamma H/c_b)$  were greater than 5.14 and the methods outlined above have been applied to the calculation of the earth pressures.

The details of the field measurements are given in Technical Reports Nos. 6, 7, 8 of the Norwegian Geotechnical Institute<sup>6-8</sup> while some of the data have been interpreted by Flaate<sup>3</sup>. In the calculations that follow Flaate's value for  $c$ , the average shear strength above the base of the excavation has been used together with his values for the measured  $K_a$ . The values of  $c_b$ , the shear strength in the plastic zone beneath the excavation, have been estimated from the data in the Technical Reports of the Norwegian Geotechnical Institute.

A section through the Vaterland I excavation is shown in Fig. 5 while the relevant field data and calculated and measured values of  $K_a$  are tabulated in Table 1.

The other site in which the conditions covered by the paper apply is in Mexico City and has been described by Rodriguez and Flamond<sup>9</sup>. The section is shown in Fig. 6 and the field data and values of  $K_a$  are given in Table 1.

The agreement between the values of  $K_a$  calculated by the new method and those measured is satisfactory. For comparison, the values of  $K_a$  found from Bell's equation are included in the table and, as can be seen, the differences between these values and those measured are very important.

## Conclusion

The method developed in the paper appears to give good agreement between calculated and measured values of earth pressure where plastic zones develop below the base of the excavation for the four sites for which data are available.

Further field data will be required to substantiate the method over a wider range of conditions but the new approach should assist the engineers in the design of excavations in soft clays.

## References

- (1) BJERRUM, L. and EIDE, O. Stability of strutted excavations in clay. *Geotechnique*, **6** (1), pp. 32-47, March 1956.
- (2) SKEMPTON, A. W. The bearing capacity of clays. Building Research Congress, London. Papers presented in Division 1. pp. 180-189, 1951.
- (3) FLAATE, K. S. Stresses and movements in connection with braced cuts in sand and clay. Ph.D Thesis, University of Illinois, 1966.
- (4) TERZAGHI, K. and PECK, R. B. Soil mechanics in engineering practice. 2nd edition, John Wiley, 1967.
- (5) PECK, R. B. State of the art report on deep excavations and tunnelling in soft ground. Proceedings of the Seventh International Conference on Soil Mechanics and Foundation Engineering, Mexico. State of the Art Volume pp. 225-290, 1969.
- (6) NORWEGIAN GEOTECHNICAL INSTITUTE. *Technical Report No. 6*. Measurements at a strutted excavation, Oslo Subway. Vaterland 1, km. 1,373. The Institute, 1962.
- (7) NORWEGIAN GEOTECHNICAL INSTITUTE. *Technical Report No. 7*. Measurements at a strutted excavation, Oslo Subway. Vaterland 2, km. 1,408. The Institute, 1962.
- (8) NORWEGIAN GEOTECHNICAL INSTITUTE. *Technical Report No. 8*. Measurements at a strutted excavation, Oslo Subway. Vaterland 3, km. 1,450. The Institute, 1962.
- (9) RODRIGUEZ, J. M. and FLAMOND, C. L. Strut loads recorded in a deep excavation in clay. Proceedings of the Seventh International Conference on Soil Mechanics and Foundation Engineering, Mexico. pp. 459-468, 1969.

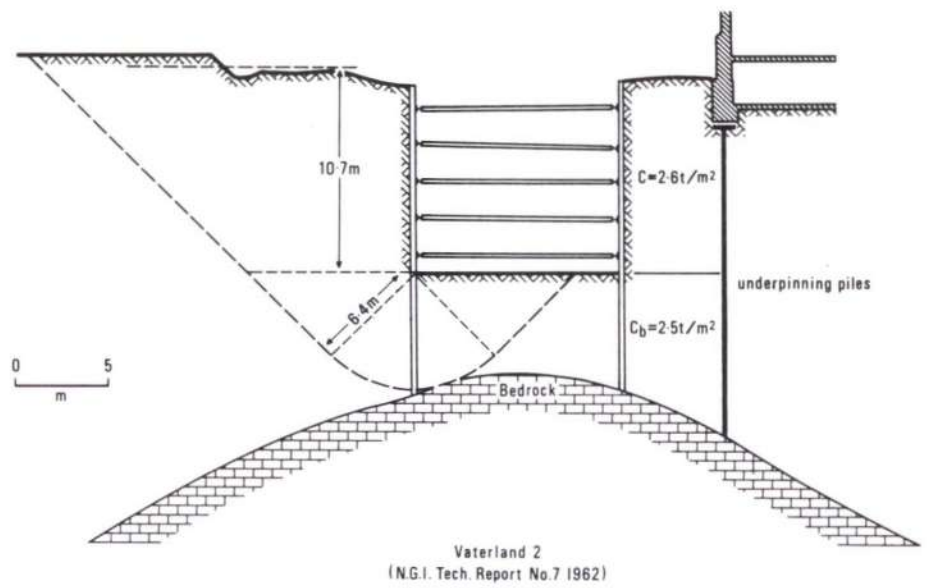

**Fig. 5**  
Section through excavation at Vaterland 2

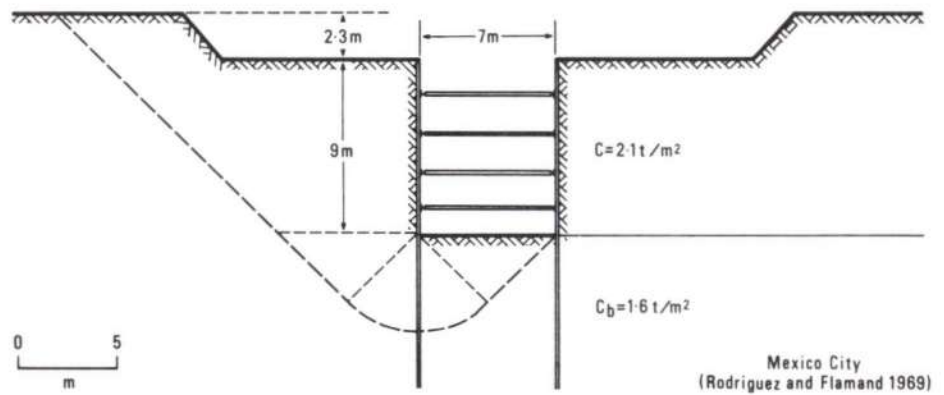

**Fig. 6**  
Section through excavation in Mexico City

